



**TWT® System Packaging Contents**

- A. TWT Microprocessor Deposit Control Unit
- B. Wire for onsite wiring & solenoid coil hookup
- C. Hardware kit: Screws, wire ties
- D. Controller mounting kit: Mounting brackets & wire ties
- E. System registration card

**Not included, sold separately:**

- Contact your dealer and/or TWT, Inc. before installation of system if application requires a–
- TWT Copper Pipe Signal Enhancer
- TWT factory wrapped Reaction Chamber
- Teflon coated wire

# OWNER APPLICATION & INSTALLATION MANUAL

## TWT® Patented Microprocessor Deposit Control System(s)

---

Commercial / Industrial

TWT-5C8-406 – Designed for pipes 6" or less in diameter

---

**Read All Instructions Carefully Before Installing the System**

To find out even more about us, and how we can help you, contact us at:  
Email: [info@triangularwave.com](mailto:info@triangularwave.com)

---

Visit Triangular Wave Technologies, Inc.'s comprehensive website,  
the valuable technical resource for all involved in water and fluid management...

[WWW.TRIANGULARWAVE.COM](http://WWW.TRIANGULARWAVE.COM)

**Bringing You The best in Fluid Management Solutions**



M44



## TWT Deposit Control Installation & Configuration Guide

### TWT Deposit Control Installation for Fluid-Fed Equipment - Determining Points of Treatment and Optimum Treatment Configurations for Commercial and Industrial Facilities and Systems

A complete TWT treatment system may use all or only some of the components of a comprehensive water treatment plan, including deposit control, filtration, purification, and disinfection. This configuration guide deals with factors to consider when selecting TWT **deposit control** models for use in a commercial or industrial environment.

Site conditions may indicate that a combination of deposit control products of varying sizes and models is most appropriate for an optimal installation. Among the factors to consider are water chemistry (hardness/grain count) process, "reaction zones", and pipe layout.

We have established that certain configurations are preferred for certain uses, and that if correctly installed in these configurations, the TWT Deposit Control Systems will deliver even greater performance than may have been previously experienced, providing the best end-to-end fluid management and treatment solutions available.

The ability of the Triangular Wave Technologies Deposit Control Systems to inhibit scale and biofilm deposits and to remove preexisting deposits is dependent upon the proper application and installation of the products purchased from TWT Inc.

*Water chemistry must be taken into consideration.*

Every application has areas called *reaction zones*. These areas represent locations in a system where the fluid is exposed to different types of changes that affect its behavior.

**Mechanical:** change in pressure, velocity, direction, flow pattern (pumps, aerators, agitators, etc.)

**Thermodynamic:** changes in temperature (heat exchangers, evaporators, boilers, spray nozzles, etc.)

**Physicochemical:** change in concentration, state (membranes, cooling towers, filters, main/makeup water inlets, etc.)

It is in the reaction zones where the particles in the fluid, due to the changes to which they are exposed, are more likely to form scale or biofouling. There are many systems, which, due to their nature, will have multiple reaction zones. In general, it is the reaction zone(s) where the TWT Deposit Control treatment should be focused. In these cases, the size and conditions of the system will play an important role in determining the need for one or multiple units, likely of varying sizes/models. (based on pipe size and material)

## Our suggested considerations for optimal installation of the TWT Deposit Control System:

The Deposit Control System will provide the means to keep deposits (calcium, lime, etc.) in solution for extended periods, if not disturbed. The ability of the fluid to retain the deposits in solution is decreased (but not eliminated) by fluid disturbances (e.g., pressure changes) high temperature conditions (flashing, boiling, etc.) and changes in concentration (fluid conditions).

In Automatic Fill Systems, a Fill Solenoid Valve/Float Valve will be used to control the fluid level in the fill system. Where a large pressure change takes place immediately downstream of the valve, TWT recommends that the Reaction Chamber and/or the on-site wrap be located downstream from the valve to avoid this pressure change point. When water boils and/or is evaporated, the calcium and other dissolved solids remain and form deposits. As a result of the TWT fluid conditioning, these deposits will be softer and more easily removed when treated by the TWT deposit control system. In most cases the heating system process and self cleaning ability will wash away any potential build up, allowing for a significant reduction in maintenance procedures.

If a heating system can be operated without boiling/flashing on the surface of the heating element, a significant reduction in deposits will be obtained. As the fluid temperature is lowered from boiling, the ability of the TWT-treated water to hold the deposits in solution increases. TWT recommends that a reaction chamber and/or onsite wrap be located upstream of (before) any heating system, and where possible downstream (after) the heating system, to further ensure the ability of the fluid to retain the deposits in solution.

***When fluid is heavily saturated with deposits*** (TDS, grain count, change in concentration/ fluid condition), the ability of the TWT Deposit Control System to treat fluids and hold deposits in solution is decreased but not eliminated. The ability of the TWT Deposit Control Treatment System effectiveness decreases proportionately with the increase in TDS. i.e., grain count, change in concentrations, evaporation and/or other fluid exposures as referred in the above "reaction Zones". That is why you must examine the water (fluid) to be treated and all of the obvious influences surrounding it to ensure proper installation & application. ***Under these conditions TWT recommends that you upsize (increase the oscillating electrical field) the Deposit Control System to meet and ensure the highest level of performance for these conditions.***

For these and other special requirements and installations, TWT, Inc., Representatives, Dealers and Distributors will work directly with you to custom design fluid management solutions and system configurations for your industry-specific needs in an operational and effective manner.

## System Layout & Unit Mounting

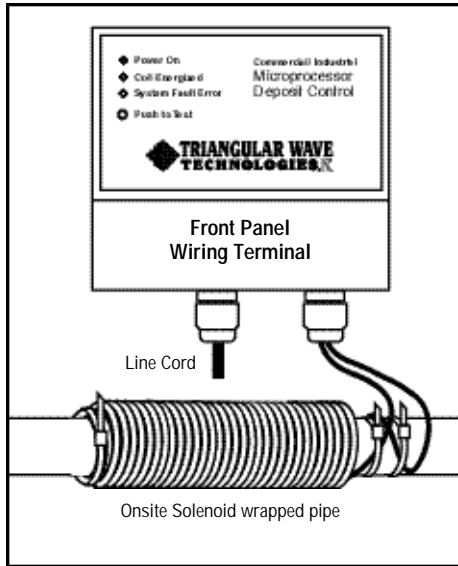

The TWT® Deposit Control System will give many years of service if installed properly. Please read all instructions carefully (owners installation manual) before assembling the system.

The unit is provided with a line cord. The cord should remain unplugged until the installation is complete. Mount the unit to a supporting structure using the base mounting flange, and case mounting kit supplied. Install two mounting feet to the top rear of controller case with screws supplied. Place one of the mounting brackets on the top corner over the locating tab on each side of the unit, attach the brackets with screws provided. The two bottom mounting holes are located inside the controller in the terminal hookup area. You need to remove the front panel to locate the mounting holes at the bottom corners of the case. With the brackets in place you have a method to fasten all four corners of the controller to an appropriate surface.

### IMPORTANT REMINDERS

#### TWT Factory Wrapped Reaction Chamber

The Triangular Wave Deposit Control System creates an electromagnetic field which is used to address the fluids in the pipe. Do not install the wire coil on any magnetic pipe, such as **STEEL, GALVANIZED STEEL, IRON, DUCTILE IRON OR CAST IRON**. When the coil is applied to a magnetic material, the pipe then becomes a shield, and prevents the energy from entering the fluid path. If the fluid pipe is magnetic, it is necessary to insert a section of non-magnetic pipe to provide the proper pipe material for the unit to work as designed (Please see Reaction Chamber Application page).

#### TWT Copper Pipe Signal Enhancer

Copper pipes, although acceptable, are one of the more difficult of materials to work with. To overcome this...TWT has developed its Copper Pipe Signal Enhancer. (Please see Copper Pipe Signal Enhancer Application page)

#### Teflon Coated Wire

For high temperature (hot water) applications of 176°F and above, request and use teflon wire. Teflon wire solenoid wrap sizes vary according to pipe material and pipe size, please contact your dealer for additional information.

**WHEN THE TWT SYSTEMS ARE PROPERLY INSTALLED, THE Effects of the Patented Triangular Wave Technology Treatment Last Downstream**

**The Triangular Wave Deposit Control System will give many years of service if sized and installed properly. Please read all instructions carefully before assembling the system.**

Introduction . . .

The Triangular Wave System is a technologically advanced method for the treatment of hard water and its effect on fluid based applications. The system is non-invasive and non-chemical by design and is suitable for all applications requiring hard water treatment.

Operating Principals . . .

The signal from the Triangular Wave System circuitry flows to a solenoid coil wound around the pipe treating and conditioning the fluid going through it. The signal in the coil develops the modulated electrical field that immediately conditions the water. The field penetrates the piping to its center, acting on the passing water and the dissolved minerals and particles in the water. The conditioning effects on the water are long lasting and last down stream.

Installation . . .

The Triangular Wave System is easy to install. A standard 110V electrical outlet is needed (unless other current source was requested prior to purchase) near the unit installation. The most desirable place to install the unit is immediately after the water meter, before any plumbing line tee, or before each piece of vital processing equipment, so that the entire plumbing system is treated for deposits. The unit may be installed outdoors at a wellhead for example, provided a separate weatherproof housing such as NEMA enclosure is used. Because the unit is a solid state device, it may be mounted in any position necessary.

Control Unit Screw Mounting

For screw mounting on a flat wooden surface or other surface, use the 4 No. 6 steel self-tapping screws provided. Alternate screw mounting to a drilled channel or plate can be done with No. 6, No. 8 or No.10 machine screws and appropriate nuts or hardware.

Select a location that is near the pipe area and/or equipment to be treated, and a location that affords the equipment protection from environmental extremes. The unit is provided with a line cord. The cord should remain unplugged until the installation is complete and the case is closed.

A standard installation will not require access to the main control circuit board, because all connections are available in the wiring terminal. The control circuit is accessed by removing the front panel of the TWT unit. (Refer to Figure 1 following page). The AC line fuses (3 AG 0.3 amp) are located on the main control printed circuit board.

#### Completed System Installation Must Reflect:

- A. Solenoid coil correctly field wrapped or factory wrapped  
Reaction Chamber / Copper Pipe Signal Enhancer Installed
- B. Visual placement of controller for periodic visual inspection of LEDs  
*All wires must be securely fastened and/or taped to connections*  
*All associated wiring/conduit/line cords must be fastened with plastic wire ties and out of harms way*

## IMPORTANT NOTES: Bypassing and/or eliminating water softeners

**Water Softeners** - Water softeners often leave deposits inside a water system; therefore, if a softener is in use, you may want to allow the Deposit Control System to remove the deposits before the softener is switched off. In that case, leave the softener and the Deposit Control System on together for about 1 month.

**Remember, install the Triangular Wave system downstream of the water softener, if you plan to run them together.**

## TWT Installation Instructions

### Onsite Solenoid Coil Winding

#### 1. Install the solenoid on non-magnetic pipe 6-inches in diameter

The finished coil of wire will be 4.5 inches long ( refer to figure 2). Measure and mark a 4.5 inch section in the middle of the pipe segment ( see step-by-step winding illustrations). Fasten the signal wire to the pipe with a cable tie (provided) at one end of the 4.5 inch section. Wrap the signal wire around the pipe in a tight coil, so that the adjacent wires are touching each other. Continue to wrap until the 4.5 inch section of pipe is completely covered. Fasten down the end of the coil with the second cable tie provided. You can hold the first layer in place with cloth tape or electrician's tape

#### Be sure:

- A. The coil is tight, and...
- B. The wire turns are side by side and touching each other.
- C. Use tape to hold the coil tight.

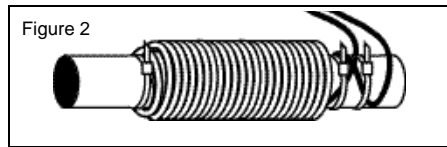

- 2. Add a second layer to the coil by continuing to wind in a clockwise manner starting where you completed the first layer and wind back in the direction of the starting point. Do Not Twist or Cut Wire or the System **WILLNOT Function**. Place the second layer directly on top of the first layer. Be careful to wind the second layer tightly in the same clockwise manner as the first layer back in the direction of the starting point.

#### Please Note:

When wrapping it does not matter if you wrap the first layer clockwise or counter clockwise, but you must wrap the second layer returning in the same direction as you started. If not the signal will be negated, and the unit will not work. ( see A step-by-step winding illustrations).

- 3. **Wrap the coil with electrician's tape or cloth tape** (duct tape) to help maintain a tight coil and protect the coil from being disturbed.
- 4. **Guide both wires back to the Triangular Wave Unit** and leave about 4 to 6 inches of extra wire. Strip enough insulation off the ends of the wires to install into the barrier terminals.
- 5. **Close the wiring trough.**
- 6. **Plug the line cord into a 120 vac outlet.**
- 7. **Green LED ( Power On ) will light.**
- 8. **Yellow LED ( Coil Energized ) will light.**
- 9. **Push and hold the "Push to Test" button to test the alarm circuit.**

- 10. **Yellow LED ( Coil Energized ) will go out.**
- 11. **Red LED ( System Fault ) will light.**
- 12. **Alarm Relay will activate.**
- 13. **Audio Alarm will sound.** The audio sounded during this test is the signal solenoid coil. The conditioning signal varies from very low to very high frequencies.
- 14. **Release the "Push to Test" button.**

An additional test should be made to check the alarm circuit for an open or disconnected coil.

- 15. **To test the circuit, disconnect one solenoid lead.**
- 16. **Yellow LED (Coil Energized) will go out.**
- 17. **Red LED (System Fault) will light.**
- 18. **Alarm relay will activate.**
- 19. **Audio will sound beep...beep...beep.**
- 20. **Reconnect the solenoid wire and your installation is complete. The unit is in service.**

## TWT Deposit Controller / Solenoid Coil Terminal Hookup

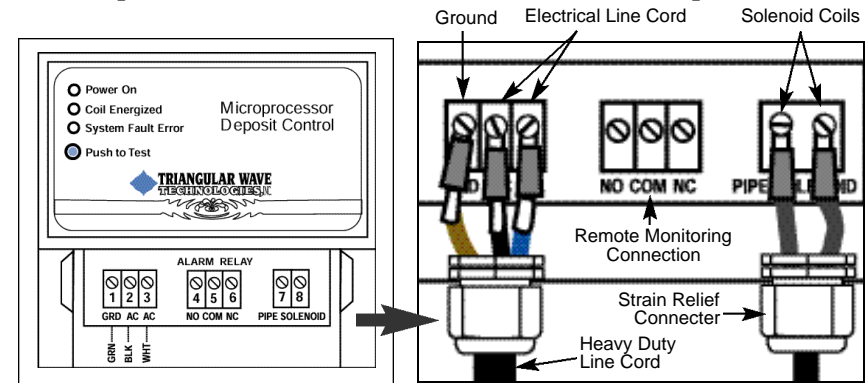

Figure 1

### TWT Deposit Control Unit

The controller is supplied with a wiring kit and a strain relief connector for the solenoid coil wires. This strain relief will provide a water resistant seal for the two coil wires. You should rotate the compression ring counter clockwise to release pressure on the seal. Feed the two wires through the provided holes and tighten the compression ring. Connect the two wires to the coil terminals in the controller housing as illustrated.

The Model TWT-5C8-402/403 and 404 are provided with an alarm relay (above), which may be used for external alarms. The relay contacts are rated 5 amps @ 120 vac. The contacts are isolated from the control circuit and are single pole double throw. If an external alarm is desired it may be connected to Barrier terminals. (Refer to Figure 1 above )

TWT Reaction Chamber/Copper Pipe Signal Enhancer terminal hookup same as above

## Step-by-Step Solenoid Coil Winding

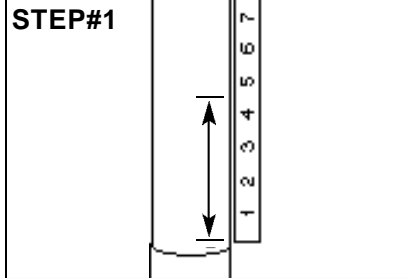

Measure and mark a 4.5 inch section in the middle of a straight pipe segment.

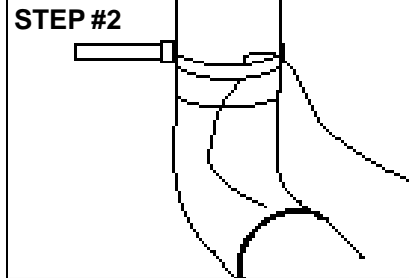

Fasten the signal wire to the pipe with a cable tie (provided) at one end of the 4.5 inch section.

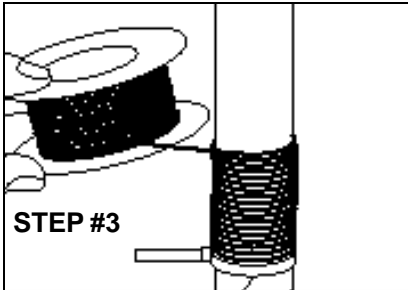

STEP #3

Wrap the signal wire around the pipe in a tight coil, in a clockwise manner, so that the adjacent wires are touching each other.

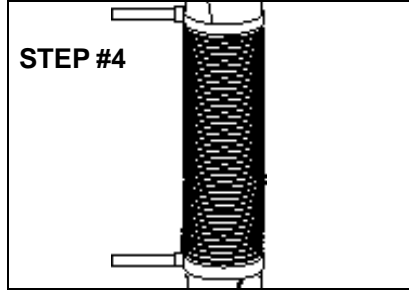

STEP #4

Continue to wrap until the 4.5 inch section of pipe is completely covered. Fasten down the end of the coil with the second cable tie (provided). You can hold the first layer in place with cloth tape or electrician's tape.

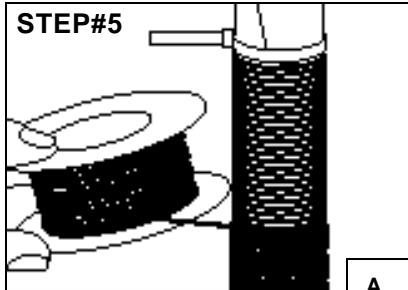

STEP #5

Add a second layer to the coil by continuing to wind in a clockwise manner starting where you completed the first layer and wind **back in the direction of the starting**

Add a second layer to the coil by continuing to wind in a clockwise manner starting where you completed the first layer and wind **back in the direction of the starting point**. (see Diagram A) **Do Not Twist or Cut Wire or the System WILL NOT Function**. Place the second layer directly on top of the first layer. Be careful to wind the second layer tightly **in the same clockwise manner** as the first layer back in the direction of the starting point.

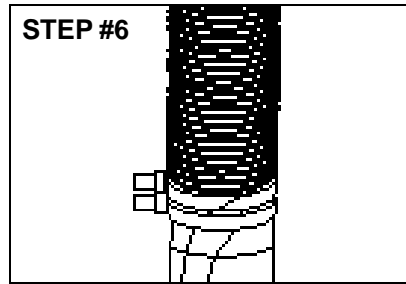
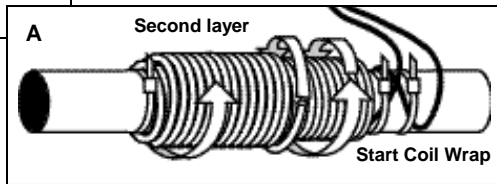

STEP #6

Complete the second layer by clamping the wire with third cable tie (provided). (See Diagram B Below Right)

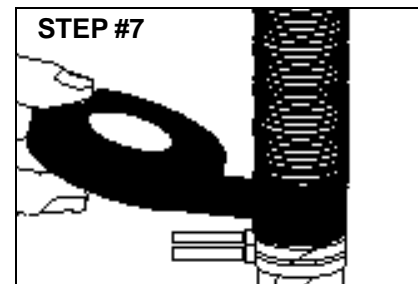

STEP #7

Wrap the coil with electrician's tape or cloth tape (duct tape) to help maintain a tight coil and protect the coil from being disturbed.

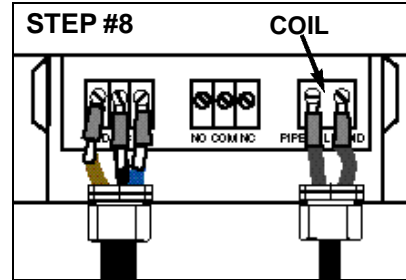

Guide both wires to the Triangular Wave Unit and leave about 4 to 6" of extra wire.

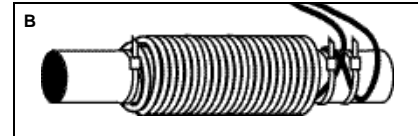

**Please Note:**

When wrapping it does not matter if you wrap the first layer clockwise or counter clockwise, but you must wrap the second layer returning in the same direction as you started. If not the signal will be negated, and the unit will not work.

## TWT-CSE Copper Pipe Signal Enhancer *For copper pipes only*

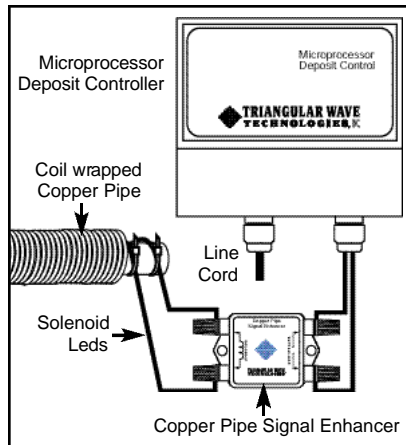

Copper pipes, although acceptable, are one of the more difficult of materials to work with. To overcome this...

TWT has developed its Copper Pipe Signal Enhancer. This unit is placed between the Deposit Controller and the solenoid coil on the copper pipe as illustrated. The function of the signal enhancer is to provide a proper impedance match and to ensure maximum energy transfer between the controller and the solenoid, which, in turn, ensures enhanced treatment of the fluid.

The copper signal enhancer is a passive signal / impedance matching circuit. The Signal Enhancer **must be** used in all copper pipe applications to maximize the performance, and provide a power boost to the conditioning signal in copper pipes.

## Factory Wrapped Wire Coil Reaction Chambers Application

- To address magnetic pipe applications • When a protected environment (code) is needed
- When on-site solenoid wrap is not applicable

To use in conjunction with the TWT Deposit Control Systems when required, Triangular Wave Technologies, Inc. has developed a line of factory-wrapped wire coil Reaction Chambers to address magnetic pipe environments. **Typically, wire coil cannot be installed on any magnetic pipe, such as steel, galvanized steel, ductile iron, or cast iron.** If a coil is applied to such a pipe, the pipe becomes a shield and prevents the wave energy from entering the fluid path. TWT Reaction Chambers solve this problem by providing an easily installed section of non-magnetic pipe to provide the proper pipe material for the Deposit Control System to work as designed. TWT Reaction Chambers are fully sealed, protecting their two layers of factory-wrapped coil. The PVC, Stainless Steel and the Industrial Reaction Chamber systems are designed and manufactured to meet the highest quality specifications necessary and to meet the needs of all Deposit Controllers.

The TWT Reaction Chamber is part of the patented TWT Deposit Control Technology. The Reaction Chamber provides a chamber through which the water flows and is exposed to the triangular wave signal that lies at the heart of the deposit control technology. As the fluid passes through, it is treated and then carries that treatment downstream, to condition the rest of the plumbing system, non-chemically and reliably.

When you have purchased a reaction chamber with cable and connectors with your controller unit, the correct strain relief connector for the controller is furnished with the cable for the reaction chamber. The strain relief connector on the controller (pipe solenoid) should be removed and replaced with the strain relief connector provided with the reaction chamber cable. The two wires should be connected to the coil terminals in the controller housing as illustrated below.

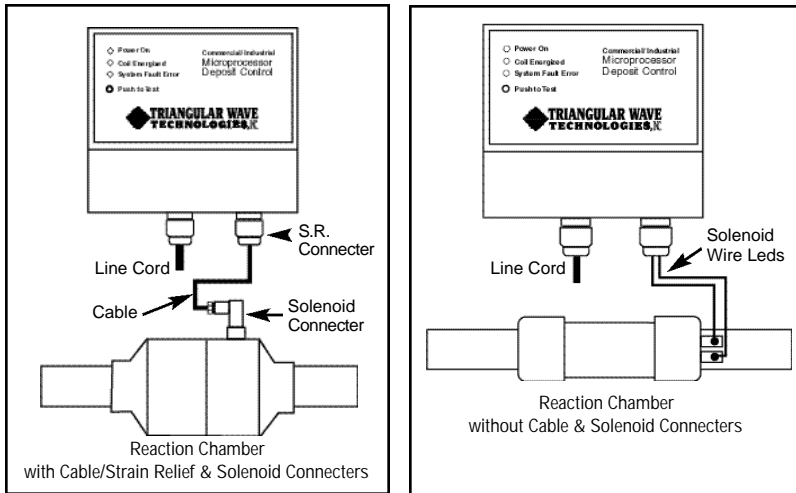

Schematic rendering of industrial reaction chamber hookup

Schematic rendering of reaction chamber hookup using wiring kit provided

## Maintenance

Your Triangular Wave Technologies Deposit Control System is manufactured in the U.S.A. with premium electronic components. No periodic maintenance is required. The front panel display indicates the status of the AC Power and Solenoid Coil. These indicators are LED's and will not require replacement. If the indicators are not correct, check the AC power and the wire to the solenoid.

For Technical Support contact us at Triangular Wave Technology Inc.

## Product Warranty

All components of the Triangular Wave Microprocessor Deposit Control Systems are covered by a Five (5) Year Warranty provided that:

1. No modifications are performed on the unit;
2. The system is installed as recommended by Triangular Wave Technologies, Inc. and
3. There is no modification or change of installation without prior consultation with Triangular Wave Technologies, Inc. or its agents.

In the unlikely event that the unit becomes non-functioning, e.g., the "power" light and/or the "coil energized" light are not receiving the signal & are not lit, please return the unit for replacement to the place of purchase, with proof of purchase information.\* The Triangular Wave System does not affect the potability or the natural mineral content of the water, as there is no direct contact with the water. Triangular Wave Technologies, Inc., therefore, accepts no responsibility for water quality.

## Performance Warranty ( 90 Days )

Triangular Wave Technologies, Inc. warrants that the Triangular Wave Microprocessor Deposit Control System will perform as indicated in this Owner's/ Installation Manual. If the product does not perform as indicated, the unit may be returned within 90 days from the invoice date for a refund of the purchase price, less the direct cost of shipping, installation.\* Customer agrees that Triangular Wave Technologies, Inc. or its agents will be given access to the equipment for 90 days in order to monitor its performance, if desired, and/or to inspect the product and installation prior to any requested return authorization.

Under no circumstances shall Triangular Wave Technologies, Inc. or its agents be liable for consequential, special, or contingent damages or other claims or demands in excess of the purchase price of its products. The Deposit Control System is non-invasive and non-chemical by design, and is suitable for nearly all applications requiring hard water treatment. The treatment process does not add anything to the fluid and should not cause damage to piping or equipment. The Deposit Control System is designed to remove scale; if piping or equipment has suffered corrosion prior to the installation of a TWT Deposit Control System, the removal of this scale may potentially reveal cracks/pin holes in this piping or equipment that had been held together by this scale. If structural damage or corrosion is suspected to exist, appropriate measures should be taken to alleviate this condition prior to or in conjunction with the installation of the TWT Deposit Controller. Equipment owners must continue to be responsible in standard infrastructure and equipment maintenance procedures as recommended by the manufacturers of all piping and fluid fed equipment.

Triangular Wave Microprocessor Deposit Control System components should be inspected, upon receipt, for damage that might occur during shipment. The carrier and Triangular Wave Technologies, Inc. or its agents must be notified immediately if damage is found.\*\* With proper care during installation and maintenance, the system will provide faithful service for many years.

\*Triangular Wave Technologies, Inc. or its Authorized Representatives must be notified prior to any return for the proper Return Authorization, conditions and procedures.

\*\*With the exception of Triangular Wave Technologies, Inc. represented products / components, which are covered by a separate standard warranty indicated in the products' Owners Installation Manual provided.

Triangular Wave Technologies, Inc. provides total support before, during, and after the installation.