

# FACTORY ASSEMBLED WATER TREATMENT SYSTEM OWNERS MANUAL

## System 1. TWT-POUS-300 Point-of-Use (P.O.U) Integrated Water Softening, Treatment and Conditioning System

Filtration • Water Softening • Patented Deposit Control Technology  
Ideal for the Beverage (Coffee) Dispensing Industry

## System 2. TWT-POUE-400 Point-of-Use (P.O.U) Point-of-Entry (POE) Integrated Water Treatment and Conditioning System

Filtration • Patented Deposit Control Technology  
Ideal for Cottages, Mobile Homes, RV's, Boats & More.

### System Design and Installation Guidelines

Please take the time and read the following suggestions before installation

#### TWT® YOUR SIMPLE AND SAFE SOLUTION

You have now purchased a technologically advanced water treatment system that with proper maintenance, will insure cleaner water for decades to come. Providing end-to-end treatment and conditioning with consistent results.

#### 1. TWT-POUS-300 Application

The TWT Integrated system should be installed at point-of-use, on or near the beverage dispensing machines requiring treatment (for water-fed lines 3/4" in diameter or less). Select a location near water feed line in an area allowing enough room on all sides of system for filter(s) replacement, visual inspection, keeping it out of harm's way (i.e., appropriate service clearances). depending upon model purchased. This will allow most maintenance procedures to be accomplished without removing the unit and filters from its mounting bracket.

#### 2. TWT-POUE-400 Application

The TWT Integrated system should be installed at P.O.U./P.O.E., near water-fed line (for water-fed lines 3/4" in diameter or less). Select a location near water feed line in an area allowing enough room on all sides of system for filter(s) replacement, visual inspection, keeping it out of harm's way (i.e., appropriate service clearances). This will allow most maintenance procedures to be accomplished without removing the unit and filters from its mounting bracket.

#### FILTRATION-

**Traps & Removes Harmful Pollutants, prevents restriction and keeps water in the plumbing system flowing**

Filters are designed to trap various kinds of debris, dirt and organic particles that will otherwise enter your equipment and/or plumbing system, restrict your water flow and create a breeding ground for bacteria. The first step in achieving clean water is to install a filtration device that effectively removes particulate matter and similar debris.

#### Filters used in TWT-POUS-300 system

1. Sediment 5-10 Micron: Pleated Washable and reusable for sediment reduction/removal
2. Resin Filter: Water softening resin filter
3. GAC: Granulated activated carbon for taste, odor, organic chemicals and chlorine reduction/removal.

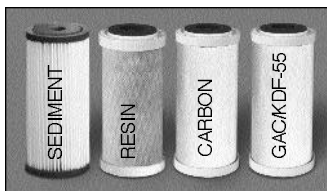

#### Filters used in TWT-POUE-400 system

1. Sediment 5-10 Micron: Pleated Washable and reusable for sediment reduction/removal
2. GAC: Granulated activated carbon for taste, odor, organic chemicals and chlorine reduction / removal
3. GAC/KDF-55: Granulated activated carbon with KDF-55, specially formulated copper/zinc alloy media designed to remove chlorine, lead, volatile organic chemicals, hydrogen sulfide, sulfur, herbicides, pesticides, chemical fertilizer residues and trihalomethanes

**Note:** See maintenance calendar



All though similar in design, the TWT-POUS-300 (above) uses a Sediment, Resin and Carbon filter. The TWT-POUE-400 uses a Sediment, Carbon and GAC-KDF-55 Filter (1-2 GPM System)

#### DEPOSIT CONTROL-

##### TWT® Patented Deposit Control Technology

The basic component in the TWT systems is the deposit controller. It is comprised of a microprocessor, solenoid coil factory wrapped reaction chamber. The microprocessor is a patented controller that functions like a computer to relay a continuous electrical power supply to the solenoid coil reaction chamber. The reaction chamber is part of the system, and provides a factory wrapped wire coil forming a solenoid. The solenoid conveys the triangular wave signal at the appropriate power level (as allowed by the model chosen) to the water passing through the chamber. This signal constantly changes the polarity, frequency, and amplitude of the current entering the water.

This triangular wave treatment produces several benefits. It increases the capability of the water to hydrate scale ions and other colloidal particles. In effect, the surface charge of the hydrogen molecules is enhanced and the water is made "wetter". This "hydrated" water can dissolve unwanted particles, suspend them in solution, and allow them to be easily filtered out or flushed from the system. Accordingly, the mineral and biological particles that cause scale, deposits, and corrosion are dissolved and washed away.



TWT Deposit Controller

This means that the breeding environments for bacteria, such as bio-film and corrosion, are eliminated. The agitation created in the reaction chamber also disrupts the conditions essential for the normal reproduction of bacteria and they die, thus allowing them to be harmlessly flushed out of the system.

#### FLOW METER-

Battery operated digital flow meter with ability to reset so users may track total flow in gallons. Offers ability to monitor multiple functions, with capacity settings 100 to 19,900 gallons. Audible alarm indicates cartridge/ media replacement.



**When the TWT systems are properly installed and maintained, the effects of the Triangular Wave Technology Treatment Last Downstream. In effect, a clean, corrosion-free delivery systems restored and maintained in a safe manner. The result is clean tanks, pipes and tubing with no bio-film and reduced bacterial contamination.**

**TWT systems make sense from operational, economic, and safety points of view. Ownership of the TWT System will afford you and/or your customers significant savings over a short period of time and even greater savings over the life cycle of the equipment.**

## BASIC INSTALLATION GUIDELINES TWT-POUS-300 / TWT-POUE-400

- Securely mount system using pre-drilled holes on beverage dispensing machine(s) or near water feed line (POU/POE) in an area allowing enough room on all sides of system for filter replacement, visual inspection, keeping it out of harms way (i.e., appropriate service clearances).
- Shut off water before you start installation at Point-of-Use
- Plumb system into to water feed line
- Test System
- Do not plug in system
- Close drain ports
- Open shut-off valves, test for leaks
- Tighten all connectors
- System should now be ready for operation
- Plug into VAC outlet, make sure manual shut off valves and drain ports are in proper position for water flow
- Allow system to operate for several minutes before using or drinking water

## COMPONENTS

- One-** factory assembled and mounted system
- One-** spanner filter wrench for filter replacement
- One-** owner's installation and maintenance manual (read before installation)

## THINGS TO DO PERIODICALLY Not less than weekly

### 1. TWT-POUS-300 Unplug AC power cord(s) before any repairs and/or replacements are performed

- Visually inspect deposit controller to ensure continuous operation
- Deposit control system LED lights should be on
- Make sure the filters are free flowing, if they become clogged you must clean or replace them
- Replace sediment and/or carbon filters when needed, generally 2 to 3 times a year, depending on water use, quality, and conditions.\*
- Replace resin filter and reset meter every 150 to 200 gallons of processed fluid (up to 20 grains), above 20 grains hardness to be determined\* (will vary based on equipment operating conditions, water quality in different areas of country. Manufactures suggest equipment owners replace resin filters more frequently until they have established appropriate usage and time tables). *See flow meter next page*
- Water Source (municipal/well), condition and GPM determines need (hard water areas of the country may require more frequent filter replacements).
- Use filter wrench (shipped with system) when replacing filters

### 2. TWT-POUE-400 Unplug AC power cord(s) before any repairs and/or replacements are performed:

- Visually inspect deposit controller to ensure continuous operation
- Deposit control system LED lights should be on
- Make sure the filters are free flowing, if they become clogged you must clean or replace them
- Replace filters when needed, generally 2 to 3 times a year, depending on water use, quality, and conditions.\*

### Meter Setting Guidelines POUE-400 (Non-Resin Filter Use):

- Set meter to max 19,900 gallons of processed water, based on a family of 4 or less, you should be able to reset meter to 19,900 again before filter replacement is needed. It is estimated the average person uses between 60 to 100 gallons of water per day (will vary based on equipment operating conditions, water quality in different areas of country. Manufactures suggest equipment owners replace filters more frequently until they have established appropriate usage and time tables).
- Water Source (municipal/well), condition and GPM determines need (hard water areas of the country may require more frequent filter replacements).
- Use filter wrench (shipped with system) when replacing filters

\*TWT Inc. recommends that owners periodically test their water and that an initial supply of replacement products e.g., replacement filters, be stored at owners facility at all times, that will insure uninterrupted service and treatment.

## SYSTEM MAINTENANCE

**Before any maintenance and/or replacement of filters is performed, follow these necessary and important steps:**

1. Unplug Power Cord
2. Close inflow & outflow shut-off valves
3. Open drain port, allowing water to drain

4. Press down pressure release valve on top of filter assembly, allowing additional drainage
5. Allow enough time for system to drain fully— **It is now safe to perform maintenance, after performing maintenance, take these necessary and important steps:**
6. Close drain port
7. Open inflow and outflow valves
8. Plug in Power Cord

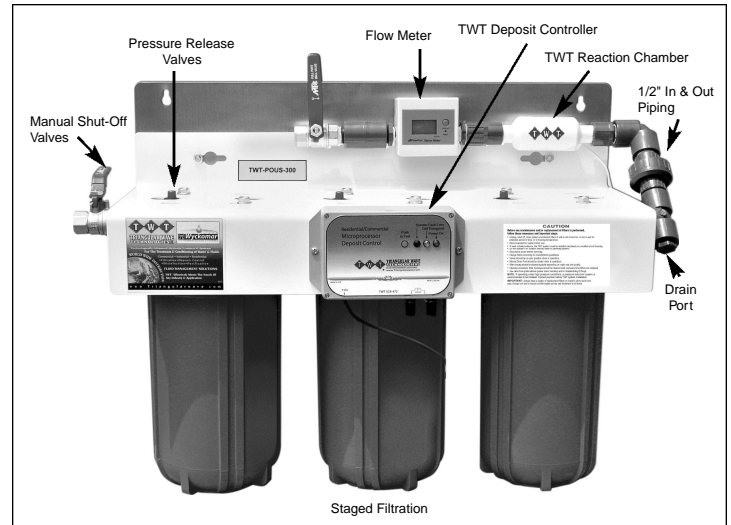

TWT-POUS-300 & POUE-400 Integrated Treatment System  
Approx Size 26\"/>

## FILTER REPLACEMENT

1. Replace filters when needed
2. Replace sediment, carbon and/or GAC/KDF-55 filters when needed, generally 2 to 3 times a year, depending on water use, quality, and conditions.\*
3. Replace resin filter every 150 to 200 gallons of processed fluid (up to 20 grains), above 20 grains hardness to be determined (will vary based on equipment operating conditions, water quality in different areas of country. Manufactures suggest equipment owners replace resin filters more frequently until they have established appropriate usage and time tables).
4. Shut down system before performing any maintenance. **READ CAUTION LABEL**
5. Turn off water supply to system.
6. Depress pressure release button to relieve pressure in filter housing.
7. Unscrew filter housings using spanner wrench (shipped with system). **NOTE:** When opening filter housing (see diagram below) to change cartridge, it is common for O-ring/Gasket to lift out of housing and stick to cap (remove carefully.)

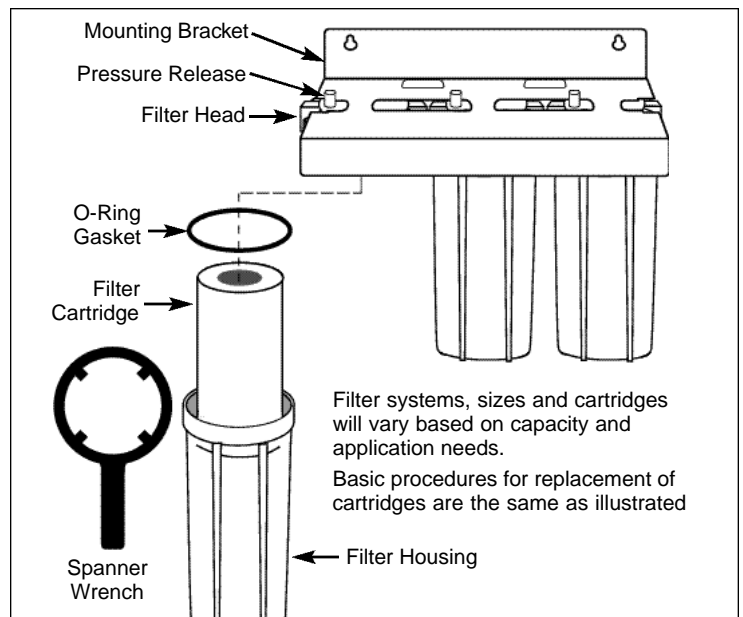

Continue Filters ➔

8. Remove used cartridge(s)/media and clean or discard. Rinse out housing and fill about 1/3 full of water. Add about 2 to 3 tablespoons of bleach and scrub thoroughly with brush or sponge. Rinse thoroughly.
  9. Remove O-ring/Gasket from housing and wipe groove and O-ring/Gasket clean. Lubricate O-ring/Gasket with a coating of clean food grade silicone grease. Place O-ring/Gasket back in place and press O-ring down into groove with two fingers (or place gasket on rim of sump (housing)).
- NOTE:** This step is important to ensure proper seals. Make sure O-ring is seated level in the groove (or gasket is on rim of sump (housing)). **CAUTION:** If O-ring/Gasket appears damaged or crimped it should be replaced at this time, contact your distributor for replacement parts.
10. Insert the new cartridge(s) into the sump (housing) making sure that it slips down into the housing.
  11. Screw the sump (housing) onto the cap and hand tighten (**DO NOT OVER TIGHTEN**).
  12. Turn on the water supply slowly to allow system to fill with water (check for leaks).
  13. Depress the pressure release button to release trapped air from filter.
  14. Restart system

## TWT DEPOSIT CONTROL TECHNOLOGY

### Performance Check . . .

1. After placing the transformer into the 110V wall outlet, check the following:
  - Power On light will be on.
  - Coil Energized lights will be on.
2. If the pipe solenoid is incorrectly connected, disconnected, or this circuit becomes open, the Triangular Wave Control Unit will indicate failure as follows:
  - Power On light will be on.
  - Coil Energized lights will be off.
3. To test the connection, unscrew one of the pipe solenoid connections (wire led) and remove the wire. Observe that the fault is correctly indicated. Replace the wire and tighten the connection. The Triangular Wave System should indicate normal operation. Your new Triangular Wave Deposit Control System is now in service.

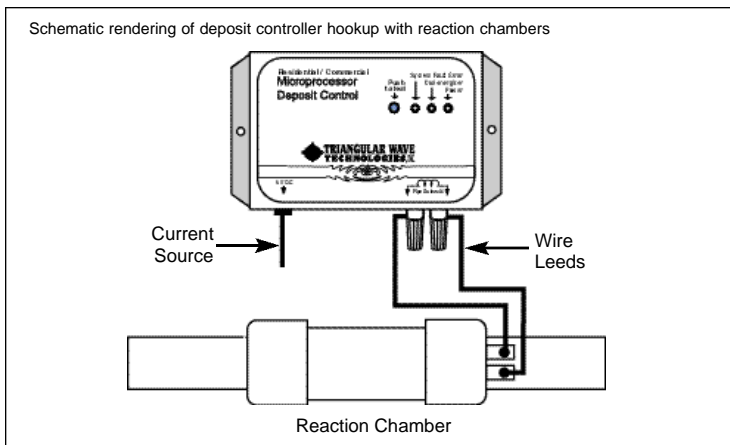

### Performance Guide . . .

The Triangular Wave Deposit Control System treats all incoming water as it passes the coil and alters the characteristics of the calcium so that it does not stick and form hard scale. It is important to remember that the calcium is still in the water and will be visible in appliances that are not subject to free flowing water.

### Your Electronic Deposit Control System Will:

1. Prevent further hard scale build-up.
2. Remove the existing scale that is inside your water system.
3. Soften the existing hard scale in plumbing lines, around taps, basins, and toilets, etc.
4. Make the water feel silkier.
5. Reduce the harsh effects of hard water on equipment, skin and clothes.

### How will you know the system is working?

The amount of time required before you experience the effects of the system varies from facility to facility, depending on the amount of water used. Generally, signs of aggressive descaling are seen within 1 to 2 weeks. Note: The system may initially seem to become "less effective" at times. This is due to the removal of the existing scale which is brought back into solution, which will briefly create the effect of increased hardness. Once the scale has been removed from the system being treated, the full effectiveness of the deposit control system will return.

## FLOW METER

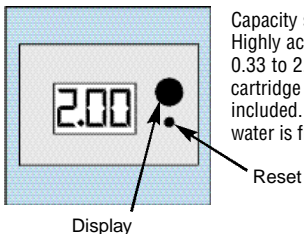

Capacity settings, with flow registered in gallons per minute. Highly accurate to 7% of setting. Flow rate indicated from 0.33 to 2.0 GPM. Audible alarm sounds to indicate when cartridge replacement is necessary. Two AAA batteries are included. Low battery alarm, with batteries used only when water is flowing.

### Operation:

**DISPLAY** button: When the meter is off, press the **DISPLAY** button to display the total accumulated gallons for the system. Press **DISPLAY** again, the meter will display the remaining gallons of each cartridge. (flash "1" twice, then the remaining gallons of the first cartridge will display. Next it will flash "2" twice and display the remaining gallons for the second cartridge...up to the third cartridge).

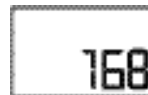

### Alarm:

When the capacity remaining reaches 0 for any cartridge, the meter will alarm to notify user to change the cartridge. (alarm only functions when there is water flowing through the meter or if the **DISPLAY** button is pressed). Press **RESET** to release the alarm and reset the cartridge setting after replacing the cartridge.



### Low Battery Power Alarm:

When the battery power is lower than the normal working level, the audible alarm will beep twice to notify you that it is time to change the battery. The data will be kept in memory when the battery power has run out or if the batteries are removed during replacement.

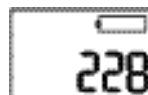

### Reset:

Depress **RESET** for 6 seconds to reset accumulated gallons to 0 and the capacity of each cartridge to its last programmed capacity setting.

### Installing Batteries (3V DC):

Slide the cover of the battery compartment and install 2 AAA batteries. Follow the instructions on the terminal for the correct installation of the positive and negative side of the battery. Replace the battery compartment cover.

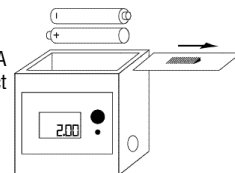

### Setting Capacity for each Cartridge:

Press and hold the **DISPLAY** button, then with a small pointed object press the **RESET** button and release both of the buttons simultaneously. The meter will go into programming mode. The right digit will flash "1" twice and the current capacity setting for cartridge one. You can set capacity for the first cartridge now.

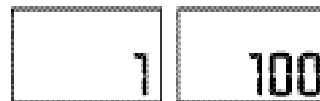

### Setting Capacity:

Press **DISPLAY** button to choose the capacity. The sequence is 0-100-200-300-19800-OFF. Choose the number gallons that relates to the capacity or change frequency you desire for your cartridge. Then press the **RESET** button to save the setting. Next, the second right digit will flash "2" twice and the current capacity setting for cartridge number 2. Following the above procedure for programming up to 3 separate cartridges.



### Battery Conservation:

To conserve battery power, the meter will be automatically off when there is no water flowing through the sensor for 10 seconds. Meter will automatically turn on when there is any water flowing through the sensor.

---

## CAUTION

---

- Unplug / shut off, drain system and discard filters if unit is out of service or not in use for extended period of time, or in freezing temperature
  - Recommended for inside/indoor use
- If used outside/outdoors, the TWT system must be installed (enclosed) in a weather proof housing
  - Do not operate TWT system without water in plumbing system
    - Disconnect power before servicing
    - Change filters according to manufacturers guidelines
    - Valves should be in open position when in operation
    - Manual Drain Port should be closed when in operation
  - Filter housings should be cleaned regularly depending on water use and quality
- Cleaning procedure: filter housings should be cleaned each and every time filters are replaced
  - Use clean food grade silicone grease when checking and/or reassembling O-Rings
- Shut down system, (on-off switch on control panel) close manual shut-off valves, and drain water from filter housings when system is not in operation.

### Note:

If operating under high pressure conditions, a pressure reduction system is recommended to be installed. Contact plumber before TWT system installation.

---

## OPTIONAL

---

- If fluid conditions require smaller micronic particle trapping for enhanced results, filters for the housings are available in various micronic sizes (providing flexibility & adaptability to meet the needs of all fluid conditions & applications).
- TWT integrated treatment systems can be upgraded (upon request) to accommodate another filter housing or larger filter housings and filters for greater capacity (filter replacement life cycle) if necessary.

### **Resin Replacement General Guidelines:**

The maximum volume of water that can be treated, depends on the hardness number. Dividing Filter capacity by hardness number will give you the approximate water in gallons achieved before need to replace or refill.  
( Filter capacity ÷ hardness # = X gallons treated )

When TWT-POUS-300 system is used for **municipal water** (chlorinated) then the position of the filter cartridges should be changed to extend the life of the resin filter. For chlorinated water, the GAC (carbon filter) should go ahead of the resin filter ( **sediment • carbon • resin** ). This will destruct much of the chlorine and therefore extend the life of the resin filter and it's softening capacity. Chlorine may damage the resin filter and reduce its capacity and effectiveness.

- TWT POUS-300 integrated treatment systems filter media and cartridge(s) use in system as illustrated. Refillable resin filter cartridge available upon request. Refill resin supplied in 1 cubic ft. bags, maintenance and replacement procedures included.

### • **Hardness test kit**

---

**In order to ensure the greatest level of performance and satisfaction with the TWT systems, if a problem occurs we recommend that you contact our engineering staff, who will be pleased to help you find the right solution.**

**TWT, Inc. offers a full range of products & systems designed to address fluid problems wherever fluid flows. From patented deposit control technology to pre and post filtration needs, ionization, disinfection, and ultraviolet purification treatment and conditioning. Components and subsystems chosen from across the range of treatment methods can be combined in different configurations to provide custom solutions specific to any industry, site or application. TWT has the versatile, efficient, cost-effective methods to solve your fluid management problems end to end.**

**NO MATTER HOW TOUGH THE JOB...TWT® IS THE SOLUTION**

---

To find out even more about us, and how we can help you,  
visit us at: [www.Triangularwave.com](http://www.Triangularwave.com)

---



Email: [info@triangularwave.com](mailto:info@triangularwave.com) • [triwaveinc@aol.com](mailto:triwaveinc@aol.com)  
Websites: [www.Triangularwave.com](http://www.Triangularwave.com) • [www.twtwatertreatment.com](http://www.twtwatertreatment.com)

---



